

YMX-60PD-345~365M

Yimeixu WitChip Energy Hitech Co., Ltd. is a leading supplier of intelligent solar energy system solutions. Yimeixu was founded in 2015 with registered capital of 45 million US dollars. It is located in Quzhou, Zhejiang Province, near Shanghai and occupies 84,000m². After years of practice, Yimeixu independently developed the series of "Sol y Smart" products including module-level MPPT smart optimization chip, smart optimizer, smart module and smart operation and maintenance system, which greatly reduced the cost of smart systems. Till the end of 2018, Yimeixu has accumulated total delivery over 3GW of mono modules.

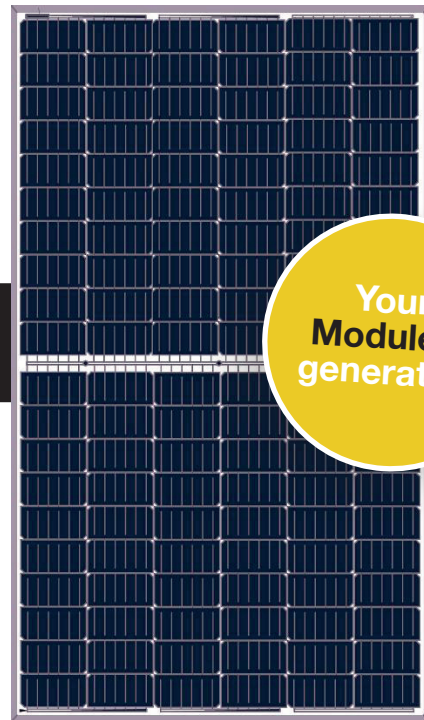

Big Cells Half-cut Bifacial PERC Modules

High Efficiency

Low LID Bifacial PERC With Half-cut Technology

Front side performance equivalent to conventional low LID mono PERC

High module conversion efficiency (up to 19.4%) Better energy yield with excellent low irradiance performance and temperature coefficient First year power degradation <2%

Bifacial technology enables additional energy harvesting from rear side (up to 25%)

Glass/glass lamination ensures 30 year product lifetime, with annual power degradation <0.45%, 1500V compatible to reduce BOS cost

30mm frame design enables easy installation and robust mechanical strength

Solid PID resistance ensured by solar cell process optimization and careful module BOM selection

Reduced resistive loss with lower operating current

Higher energy yield with lower operating temperature

Reduced hot spot risk with optimized electrical design and lower operating current

Complete System and Product Certificates

IEC 61215 , IEC 61730 , IEC 62804-1: CQC , CE , TUV , PID
 ISO 9001: 20 15 : ISO Quality Management System
 ISO 14 001: 20 15 : ISO Environment Management System
 OHSAS 18001: Occupational Health and Safety Management System



15-year Warranty for Materials and Processing, 30-year Warranty for Linear Power Output

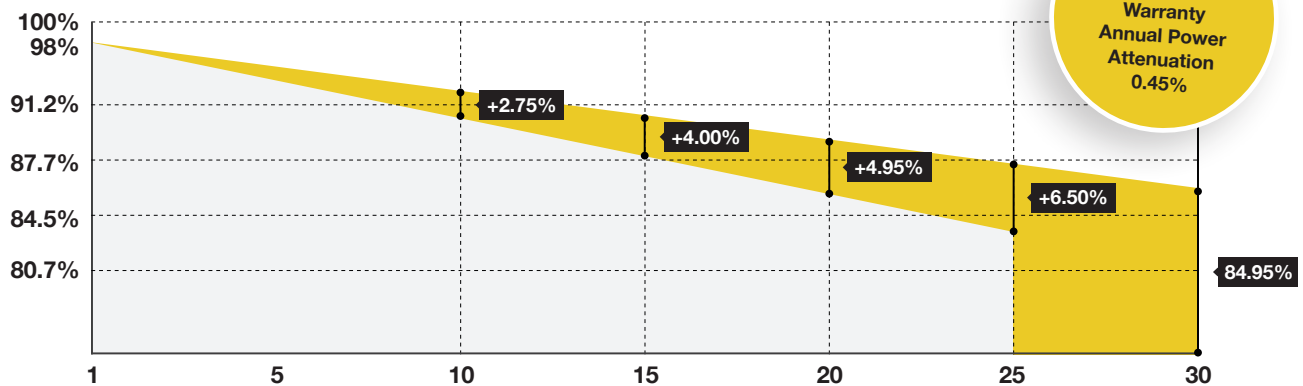

Standard Module Linear Power Warranty
 Additional value from YMX's Linear Warranty

Design (unit: mm)

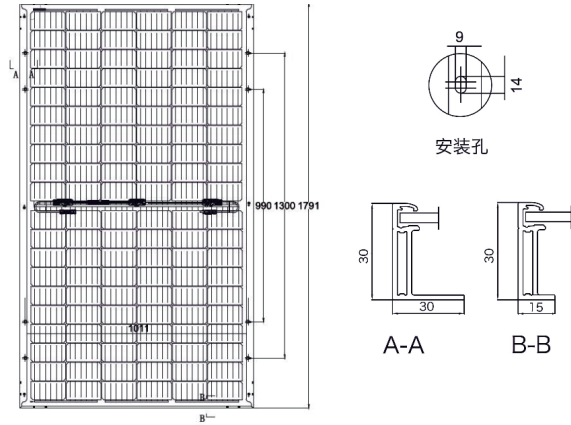

Mechanical Parameters

Number of cells: 120 (6×20)

Junction Box: IP68, 3 diodes

Output Cable: 4mm², 300mm in length, length can be customized

Connector: MC4 or compatible with MC4

Glass: Dual Glass 2.0mm tempered glass

Weight: 24kg

Dimension: 1791×1052×30mm

Packaging: 35pcs per pallet, 210pcs/20'GP, 840pcs/40'HC

Operating Parameters

Operating Temperature: -40°C~ +85°C

Power Output Tolerance: 0 ~ +5W

Voc and Isc Tolerance: ±3%

Max System Voltage: DC1500V (IEC)

Maximum Series Fuse Fuse: 20A

NOCT: 45±2°C

Safety Class: Class II

Electrical Characteristics

Test uncertainty for Pmax: ±3%

Module Type	YMX-60PD-345M		YMX-60PD-350M		YMX-60PD-355M		YMX-60PD-360M		YMX-60PD-365M	
	STC	NOCT	STC	NOCT	STC	NOCT	STC	NOCT	STC	NOCT
Maximum Power(Pmax/W)	345	256.5	350	260.3	355	264.0	360	267.7	365	271.4
Open Circuit Voltage(Voc/V)	40.7	37.9	40.9	38.1	41.1	38.3	41.3	38.5	41.5	38.7
Short Circuit Current(Isc/A)	10.88	8.81	10.96	8.87	11.04	8.94	11.11	8.99	11.18	9.05
Maximum Power Voltage(Vmp/V)	33.7	31.3	33.9	31.5	34.1	31.7	34.3	31.8	34.5	32.0
Maximum Power Current(Imp/A)	10.24	8.20	10.33	8.27	10.42	8.35	10.50	8.41	10.58	8.47
Module Efficiency(%)	18.3	/	18.6	/	18.8	/	19.1	/	19.4	/

STC (Standard Testing Condition): Irradiance 1000W/m², Cell Temperature 25°C, Air Mass 1.5

NOCT (Nominal Operating Cell Temperature): Irradiance 800W/m², Ambient Temperature 20°C, Air Mass 1.5, Wind Speed 1m/s

Electrical characteristics with different rear side power gain (reference to 305W front)

Pmax (W)	Voc (V)	Isc (A)	Vmp (V)	Imp (A)	Pmax gain
373	41.1	11.59	34.1	10.94	5%
391	41.1	12.14	34.1	11.46	10%
408	41.2	12.70	34.2	11.98	15%
426	41.2	13.25	34.2	12.50	20%
444	41.2	13.80	34.2	13.03	25%

Temperature Coefficient (STC)

Temperature Coefficient of Isc +0.060%/°C

Temperature Coefficient of Voc -0.300%/°C

Temperature Coefficient of Pmax -0.370%/°C

Mechanical Loading

Maximum Front Static Load (Wind or Snow) 5400Pa

Maximum Rear Static Load (Wind) 2400Pa

Hailstone Test 25mm Hailstone at the speed of 23m/s

I-V Curve

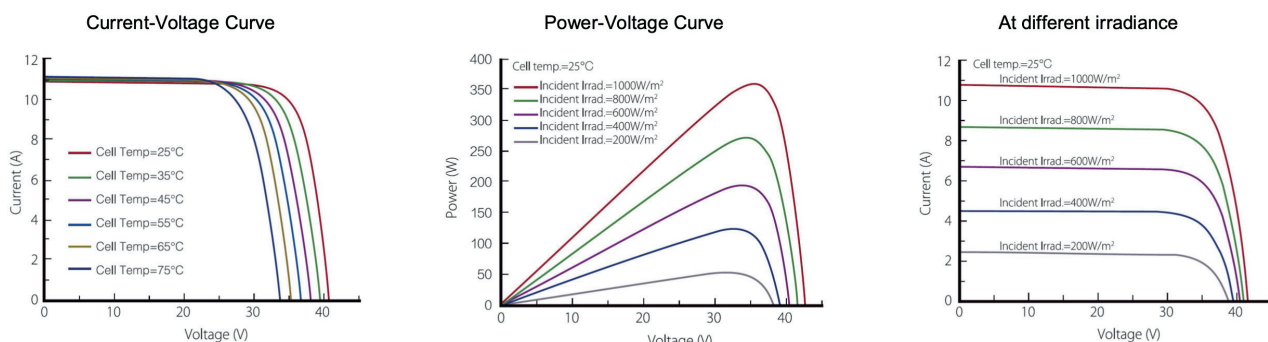

* Note: Due to continuous technical innovation, R&D and improvement, technical data above mentioned may be of modification accordingly. Yimeixu have the sole right to make such modification at anytime without further notice; Demanding party shall request for the latest datasheet for such as contract need, and make it a consisting and binding part of lawful documentation duly signed by both parties.